



# Mathematics

## National 5 Practice Paper D

### Paper 1

Duration - 1 hour

Total marks - 40

- You may NOT use a calculator
- Attempt all the questions.
- Use **blue** or **black** ink.
- Full credit will only be given to solutions which contain appropriate working.
- State the units for your answer where appropriate.

## FORMULAE LIST

The roots of are  $ax^2 + bx + c = 0$   $x = \frac{-b \pm \sqrt{b^2 - 4ac}}{2a}$

Sine rule:  $\frac{a}{\sin A} = \frac{b}{\sin B} = \frac{c}{\sin C}$

Cosine rule:  $a^2 = b^2 + c^2 - 2bc \cos A$  or  $\cos A = \frac{b^2 + c^2 - a^2}{2bc}$

Area of a triangle:  $A = \frac{1}{2}ab \sin C$

Volume of a Sphere:  $V = \frac{4}{3}\pi r^3$

Volume of a cone:  $V = \frac{1}{3}\pi r^2 h$

Volume of a pyramid:  $V = \frac{1}{3}Ah$

Standard deviation:  $s = \sqrt{\frac{\sum(x-\bar{x})^2}{n-1}} = \sqrt{\frac{\sum x^2 - (\sum x)^2/n}{n-1}}$ , where  $n$  is the sample size.

1. Find the gradient of the straight line joining points A(3, -7) and B(-5, 3) 2

2. Evaluate  $\frac{2}{5}$  of  $3\frac{1}{2} + \frac{4}{5}$  3

3.

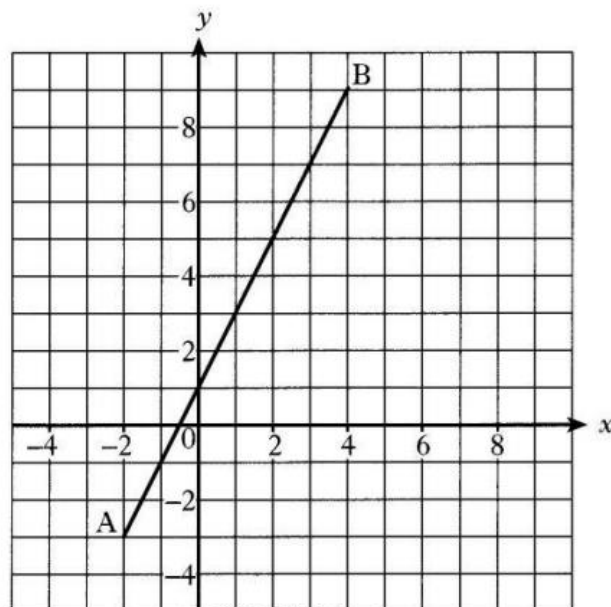

Find the equation of the straight line AB. 3

4. The marks scored by a group of students in their October test are listed below.

41    56    68    59    43    37    70    58    61    47    75    66

(a) Calculate:

(i) The median mark;

(ii) The semi-interquartile range for the data.

2

The teacher arranges extra revision classes for the students before their next test in December.

In this test the median mark is 67 and the semi-interquartile range is 7.

(b) Make two appropriate comments comparing the marks in the October and December tests.

2

5. Marmalade is on special offer.

Each jar on special offer contains 12.5% more than the standard jar.



A jar on special offer contains 450 g of marmalade.

How much does the standard jar contain?

3

6. The diagram shows a square based pyramid PQRST.

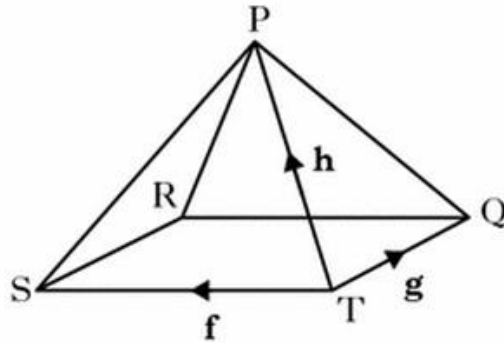

Express  $\overrightarrow{RP}$  in terms of  $f, g$  and  $h$ .

3

7. William Watson Fast Foods use a logo based on parts of three identical parabolas.

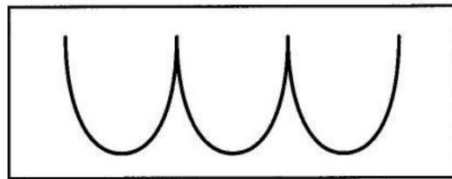

The logo is represented on the diagram below.

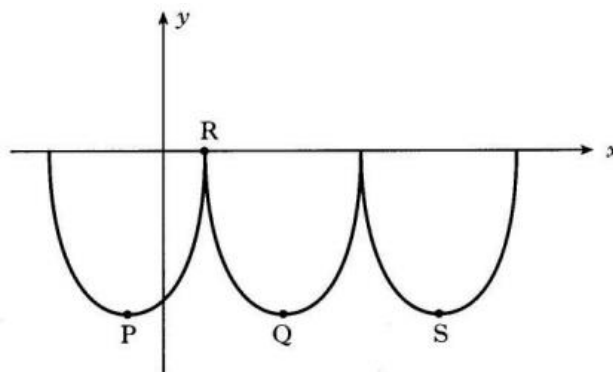

The first parabola has turning point P and equation  $y = (x + 2)^2 - 16$

- (a) State the coordinates of P. 2
- (b) If R is the point (2,0), find the coordinates of Q, the minimum turning point of the second parabola. 1
- (c) Find the equation of the parabola with turning point S. 2

8. Write  $\frac{3}{m} + \frac{4}{(m+1)}$  as a single fraction in its simplest form.

3

9. Part of the graph of  $y = a \cos bx^\circ$  is shown in the diagram.

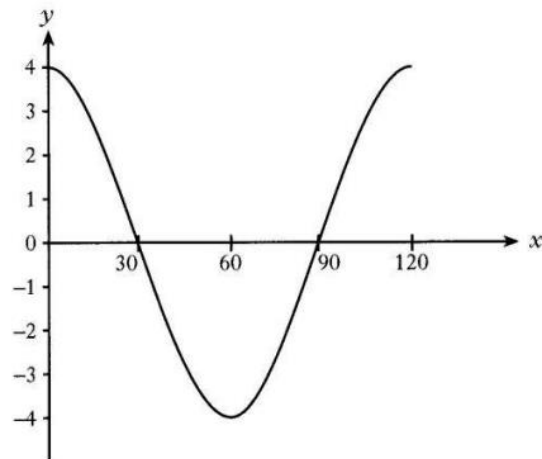

State the values of  $a$  and  $b$ .

2

10. Evaluate  $2^0 + 3^{-1}$ .

2

11. Express  $\sqrt{12} + 5\sqrt{3} - \sqrt{27}$  as a surd in its simplest form.

3

12. A piece of gold wire 10 centimetres long is made into a circle.

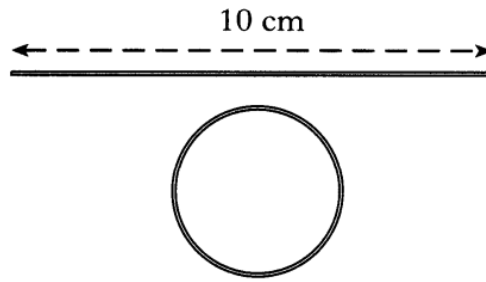

The circumference of the circle is equal to the length of the wire.

Show that the area of the circle is exactly  $\frac{25}{\pi}$  square centimetres.

4

13. Two variables  $x$  and  $y$  are connected by the relationship  $y = ax + b$ .

Sketch a possible graph of  $y$  against  $x$  to illustrate this relationship when  $a$  and  $b$  are both less than zero.

3

**[End of question paper]**



# Mathematics

## National 5 Practice Paper D

### Paper 2

Duration - 1 hour and 30 minutes

Total marks - 50

- You may use a calculator
- Attempt all the questions.
- Use **blue** or **black** ink.
- Full credit will only be given to solutions which contain appropriate working.
- State the units for your answer where appropriate.



- Q1. The average Scottish house price is £153 100.  
The average price is expected to rise by 2.5% per month.  
What will the average Scottish house price be in 3 months?  
Give your answer correct to three significant figures. 3

- Q2. The heights, in millimetres, of six seedlings are given below.

15    18    14    17    16    19

- (a) Calculate:
- (i) the mean; 1
  - (ii) the standard deviation; 3
- of these heights.  
Show clearly all your working.
- (b) Later the same six seedlings are measured again.  
Each has grown by 4 millimetres.
- State:
- (i) the mean; 1
  - (ii) the standard deviation; 1
- of these new heights.

- Q3. Solve algebraically the equation
- $$4 \sin x^\circ + 1 = -2 \qquad 0 \leq x < 360. \qquad \qquad \qquad 3$$

Q4. A sports centre charges different entrance fees for adults and children.

- (a) One evening 14 adults and 4 children visited the sports centre.  
The total collected in entrance fees was £55.00.

Let  $x$  pounds be the adult entrance fee and  $y$  pounds be the child's entrance fee.

Write down an equation in  $x$  and  $y$  to describe the above information. 1

- (b) The following evening 13 adults and 6 children visited the sports centre.  
The total collected in entrance fees was £54.50.

Write down a second equation in  $x$  and  $y$ . 1

- (c) Calculate the entrance fee for an adult and the entrance fee for a child. 4

Q5. The diagram below shows part of a parabola with equation of the form

$$y = (x + a)^2 + b.$$

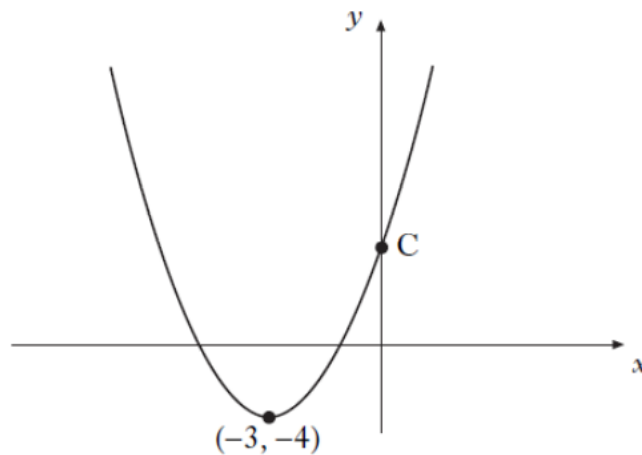

- (a) Write down the equation of the axis of symmetry of the graph. 1
- (b) Write down the equation of the parabola. 2
- (c) Find the coordinates of C. 2

Q6. A garden, in the shape of a quadrilateral, is represented in the diagram.

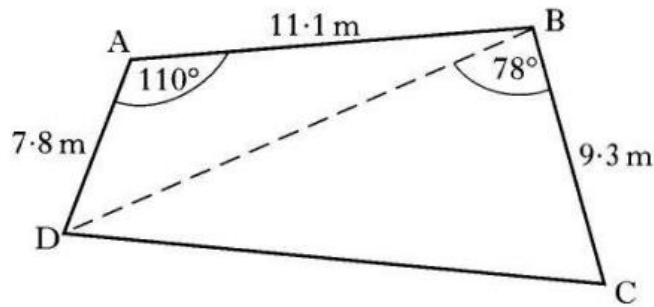

Calculate:

- (a) the length of the diagonal BD;  
Do not use a scale drawing.
- (b) the area of the garden.

3

Q7. The curved part of a doorway is an arc of a circle with radius 500 millimetres and centre C.

The height of the doorway to the top of the arc is 2000 millimetres.

The vertical edge of the doorway is 1800 millimetres.

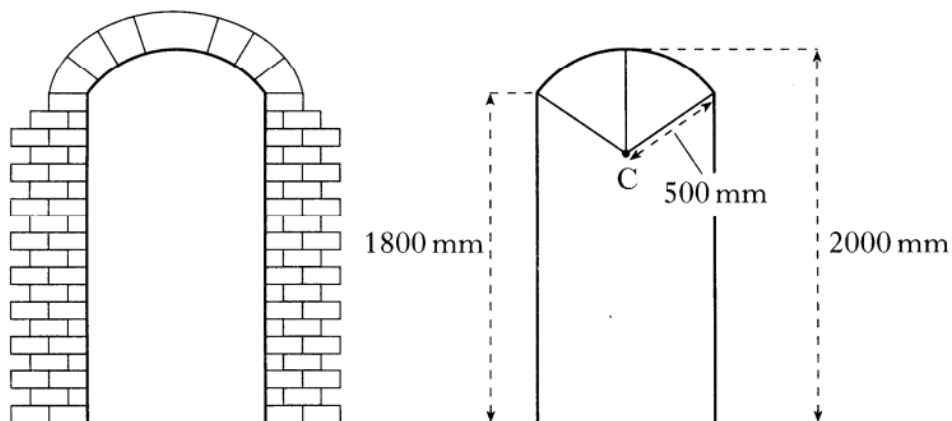

Calculate the width of the doorway.

5

Q8. Find the values of  $k$  such that the equation  $2x^2 - kx + 2 = 0$  has equal roots. 4

Q9. A gift box, 8 centimetres high, is prism shaped.

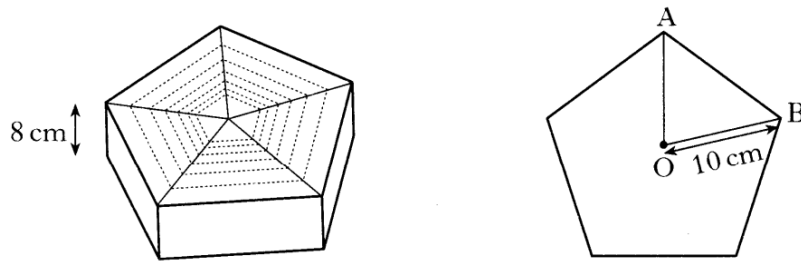

The uniform cross-section is a regular pentagon.

Each vertex of the pentagon is 10 centimetres from the centre  $O$ .

Calculate the volume of the box.

5

Q10. Express  $\frac{4}{x+3} + \frac{3}{x}$ ,  $x \neq -3, x \neq 0$ , as a fraction in its simplest form. 3

Q11. A rectangular lawn has a path, 1 metre wide, on 3 sides as shown.

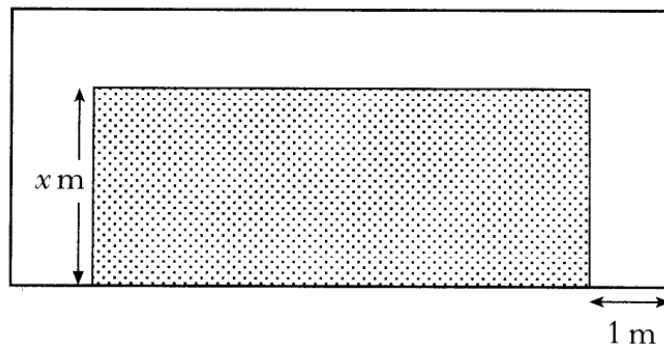

The breadth of the lawn is  $x$  metres.

The length of the lawn is three times its breadth.

The area of the lawn equals the area of the path.

(a) Show that  $3x^2 - 5x - 2 = 0$ . 3

(b) Hence find the **length** of the lawn. 4

[End of question paper]